

# ARMONIA

instructions / montage

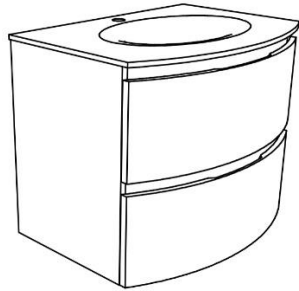

Armonia 70 cm

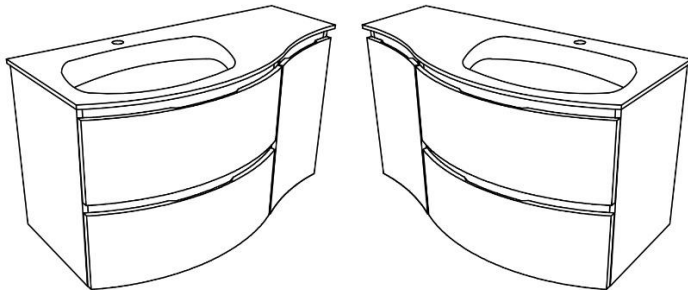

Armonia 105 cm  
70 cm + 35 cm

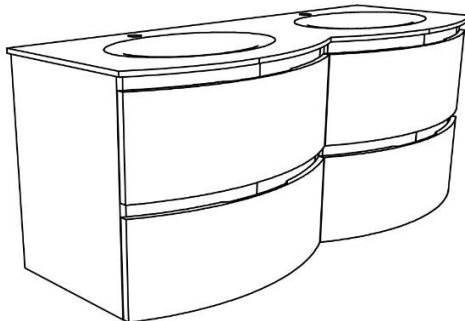

Armonia 140 cm

**L**

**R**

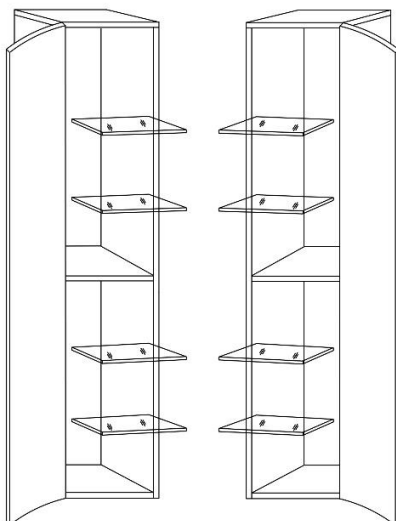

Armonia CU335

I.

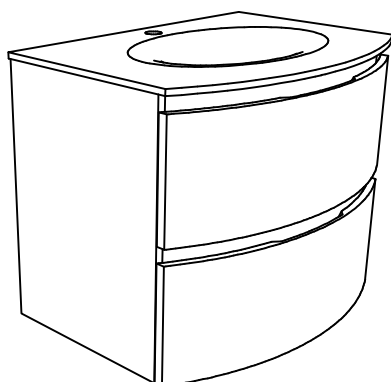

AR72-GW  
AR72-WM  
AR72-BM  
AR72-NM  
AR72-RO  
AR72-SA

AR-70-WB-GW

II.

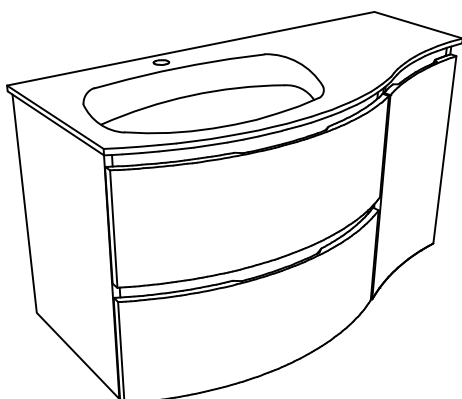

AR72-GW  
AR72-WM  
AR72-BM  
AR72-NM  
AR72-RO  
AR72-SA

AR-35-BA-DX-GW EAN: 5945846364822  
AR-35-BA-DX-WM EAN: 5945846347474  
AR-35-BA-DX-BM EAN: 5945846347511  
AR-35-BA-DX-NM EAN: 5945846347498  
AR-35-BA-DX-RO EAN: 5945846347535  
AR-35-BA-DX-SA EAN: 5945846347450

AR-105-WB-SX-GW EAN:5945846347566

III.

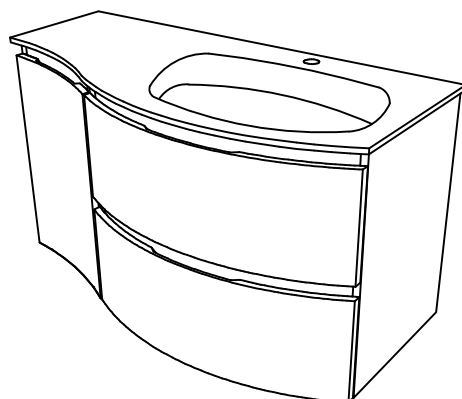

AR72-GW  
AR72-WM  
AR72-BM  
AR72-NM  
AR72-RO  
AR72-SA

AR-35-BA-SX-GW EAN: 5945846364877  
AR-35-BA-SX-WM EAN: 5945846347481  
AR-35-BA-SX-BM EAN: 5945846347528  
AR-35-BA-SX-NM EAN: 5945846347504  
AR-35-BA-SX-RO EAN: 5945846347542  
AR-35-BA-SX-SA EAN: 5945846347467

AR-105-WB-DX-GW EAN:5945846347573

IV.

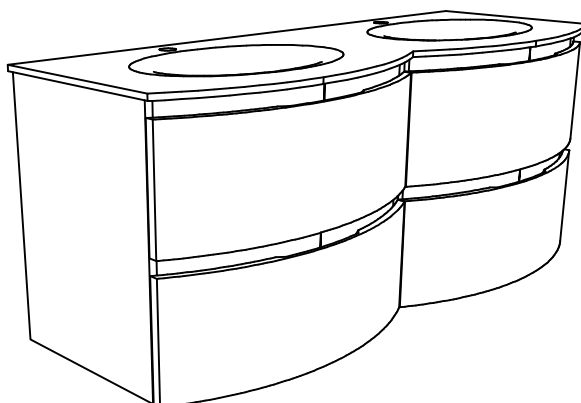

AR72-GW  
AR72-WM  
AR72-BM  
AR72-NM  
AR72-RO  
AR72-SA

AR-140-WB-GW EAN:5945846365126

**[RO]** Mobilierul trebuie fixat de perete. Pachetul nu contine diblurile si suruburile de fixare pe perete. Acestea se aleg in functie de tipul peretelui. Se vor folosi kituri de montaj speciale pentru fixarea lavoarului existente in magazinele de specialitate. Pentru fixarea lavoarului de corp utilizati silicon sanitar. Daca nu esti sigur solicita ajutor calificat. Racordarea la rețeaua apă/canal a mobilierului este obligatoriu sa fie executata exclusiv de personal autorizat. Distribuitor: S.C. Savinidue S.R.L.

**[EN]** The furniture must be fixed to the wall. The package does not contain the wall fixing dowels and screws. These are chosen depending on the type of wall. Special mounting kits for fixing the washbasin available in specialist stores will be used. To fix the washbasin to the body, use sanitary silicone. If you are not sure, ask for qualified help. The connection of the furniture to the water/sewer network must be carried out exclusively by authorised personnel. Distribuitor: S.C. Savinidue S.R.L.

**[IT]** Il mobile deve essere fissato alla parete. La confezione non contiene tasselli e viti per il fissaggio a parete. Questi vengono scelti in base al tipo di parete. Per il fissaggio del lavabo verranno utilizzati appositi kit di montaggio, disponibili nei negozi specializzati. Per fissare il lavabo al corpo, utilizzare silicone sanitario. In caso di dubbi, chiedere assistenza qualificata. Il collegamento del mobile alla rete idrica/fognaria deve essere effettuato esclusivamente da personale autorizzato. Distributore: S.C. Savinidue S.R.L.

**[HU]** A bútort a falhoz kell rögzíteni. A csomag nem tartalmazza a fali rögzítő tipliket és csavarokat. Ezeket a fal típusától függően kell kiválasztani. A mosdó rögzítéséhez speciális rögzítőkészleteket kell használni, amelyek szaküzletekben kaphatók. A mosdó testhez rögzítéséhez szaniter szilikont használjon. Ha nem biztos benne, kérjen szakképzett segítséget. A bútör víz/csatornahálózathoz való csatlakoztatását kizárólag képzett szakember végezheti. Elosztó: S.C. Savinidue S.R.L.

**[GR]** Τα έπιπλα πρέπει να στερεωθούν στον τοίχο. Η συσκευασία δεν περιέχει τα ούπα και τις βίδες στερέωσης στον τοίχο. Αυτά επιλέγονται ανάλογα με τον τύπο του τοίχου. Θα χρησιμοποιηθούν ειδικά κιτ στερέωσης για τη στερέωση του νιπτήρα που διατίθενται σε εξειδικευμένα καταστήματα. Για να στερεώσετε τον νιπτήρα στο σώμα, χρησιμοποιήστε σιλικόνη υγιεινής. Εάν δεν είστε σίγουροι, ζητήστε εξειδικευμένη βοήθεια. Η σύνδεση των επίπλων στο δίκτυο ύδρευσης/αποχέτευσης πρέπει να πραγματοποιείται αποκλειστικά από εξουσιοδοτημένο προσωπικό. Διανομέας: S.C. Savinidue S.R.L.

**[DE]** Das Möbelstück muss an der Wand befestigt werden. Dübel und Schrauben zur Wandbefestigung sind nicht im Lieferumfang enthalten. Diese werden je nach Wandbeschaffenheit ausgewählt. Zur Befestigung des Waschbeckens werden spezielle, im Fachhandel erhältliche Montagesets verwendet. Zur Befestigung des Waschbeckens am Korpus verwenden Sie Sanitär silikon. Im Zweifelsfall wenden Sie sich an qualifiziertes Fachpersonal. Der Anschluss des Möbelstücks an das Wasser-/Abwassernetz darf ausschließlich von autorisiertem Fachpersonal durchgeführt werden. Verteiler: S.C. Savinidue S.R.L.

**[FR]** Le meuble doit être fixé au mur. Les chevilles et vis de fixation murale ne sont pas incluses dans le colis. Le choix de ces éléments dépend du type de mur. Des kits de fixation spéciaux pour la fixation du lavabo, disponibles en magasin spécialisé, seront utilisés. Pour fixer le lavabo au corps, utilisez du silicone sanitaire. En cas de doute, faites appel à un professionnel. Le raccordement du meuble au réseau d'eau/d'égout doit être effectué exclusivement par un professionnel agréé. Distributeur: S.C. Savinidue S.R.L.

**[NL]** Het meubel moet aan de muur worden bevestigd. De verpakking bevat geen muurbevestigingspluggen en schroeven. Deze worden gekozen afhankelijk van het type muur. Er worden speciale montagesets gebruikt voor de bevestiging van de wastafel, verkrijgbaar in speciaalzaken. Gebruik sanitaire siliconen om de wastafel aan de behuizing te bevestigen. Vraag bij twijfel om deskundige hulp. De aansluiting van het meubel op het waterleidingnet/riool mag uitsluitend worden uitgevoerd door bevoegd personeel. Distributeur: S.C. Savinidue S.R.L.











**[SK]** Nábytok musí byť pripevnený k stene. Balenie neobsahuje hmoždinky a skrutky na upevnenie na stenu. Tie sa vyberajú v závislosti od typu steny. Na upevnenie umývadla sa použijú špeciálne montážne sady, ktoré sú dostupné v špecializovaných predajniach. Na upevnenie umývadla k korpusu použite sanitárny silikón. Ak si nie ste istí, požiadajte o odbornú pomoc. Pripojenie nábytku k vodovodnej/kanalizačnej sieti musí vykonať výlučne autorizovaný personál. Distribútor: S.C. Savinidue S.R.L.

**[SR]** Намештај мора бити причвршћен за зид. Паковање не садржи типле и завртње за причвршћивање на зид. Они се бирају у зависности од врсте зида. Користиће се посебни комплети за монтажу умиваоника доступни у специјализованим продавницама. За причвршћивање умиваоника за тело користите санитарни силикон. Ако нисте сигурни, потражите квалификовану помоћ. Прикључак намештаја на водоводну/канализациону мрежу мора да изврши искључиво овлашћено особље. Дистрибутер: S.C. Savinidue S.R.L.

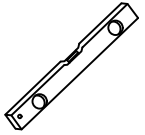
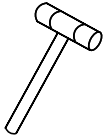
**[ES]** El mueble debe fijarse a la pared. El paquete no incluye los tacos ni los tornillos de fijación. Estos se eligen según el tipo de pared. Se utilizarán kits de montaje especiales para la fijación del lavabo, disponibles en tiendas especializadas. Para fijar el lavabo al cuerpo, utilice silicona sanitaria. Si tiene dudas, solicite ayuda profesional. La conexión del mueble a la red de agua/alcantarillado debe ser realizada exclusivamente por personal autorizado. Distribuitor: S.C. Savinidue S.R.L.

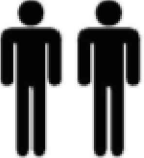
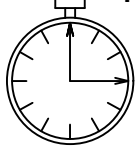
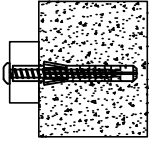
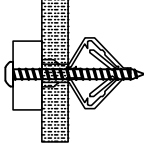
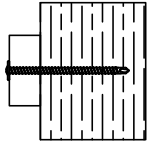
**[PT]** O móvel deve ser fixado à parede. A embalagem não inclui buchas e parafusos para fixação à parede. Estes são escolhidos de acordo com o tipo de parede. Serão utilizados kits de montagem especiais para a fixação do lavatório, disponíveis em lojas especializadas. Para fixar o lavatório ao corpo, utilize silicone sanitário. Em caso de dúvida, procure ajuda qualificada. A ligação do móvel à rede de água/esgotos deve ser efetuada exclusivamente por pessoal autorizado. Distribuitor: S.C. Savinidue S.R.L.

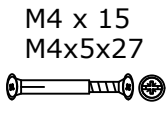
- [DA]** Møblerne skal fastgøres til væggen. Pakken indeholder ikke vægbeslag og skruer. Disse vælges afhængigt af vægtypen. Der anvendes specielle monteringssæt til fastgørelse af håndvasken, som kan købes i specialforretninger. Brug sanitær silikone til at fastgøre håndvasken til væggen. Hvis du er i tvivl, kan du bede om kvalificeret hjælp. Tilslutning af møblet til vand-/kloaknettet må udelukkende udføres af autoriseret personale. Distributør: S.C. Savinidue S.R.L.
- [SV]** Möbeln måste fästas i väggen. Paketet innehåller inte väggfästen och skruvar. Dessa väljs beroende på väggtyp. Speciella monteringssatser för fixering av handfatet, som finns i specialbutiker, kommer att användas. För att fästa handfatet i stommen, använd sanitetssilikon. Om du är osäker, be om kvalificerad hjälp. Anslutningen av möbeln till vatten-/avloppsnetet får endast utföras av behörig personal. Distributör: S.C. Savinidue S.R.L.
- [PL]** Mebel należy przymocować do ściany. Zestaw nie zawiera kołków i wkrętów do mocowania do ściany. Należy je dobrać w zależności od rodzaju ściany. Do montażu umywalki należy użyć specjalnych zestawów montażowych dostępnych w sklepach specjalistycznych. Do montażu umywalki należy użyć silikonu sanitarnego. W razie wątpliwości należy zwrócić się o pomoc do wykwalifikowanego personelu. Podłączenie mebla do sieci wodno-kanalizacyjnej może być wykonane wyłącznie przez osoby posiadające odpowiednie uprawnienia. Dystrybutor: S.C. Savinidue S.R.L.
- [CS]** Nábytek musí být připevněn ke zdi. Balení neobsahuje hmoždinky a šrouby pro upevnění na zeď. Ty se volí v závislosti na typu zdi. Pro upevnění umyvadla se použijí speciální montážní sady, které jsou k dostání ve specializovaných prodejnách. K upevnění umyvadla k tělesu použijte sanitární silikon. V případě pochybností požádejte o odbornou pomoc. Připojení nábytku k vodovodní/kanalizační síti musí být provedeno výhradně autorizovaným personálem. Distributor: S.C. Savinidue S.R.L.
- [NO]** Møblene må festes til veggen. Pakken inneholder ikke veggfesteplugg og skruer. Disse velges avhengig av veggtype. Spesielle monteringssett for feste av servanten, som er tilgjengelige i spesialforretninger, vil bli brukt. For å feste servanten til veggen, bruk sanitær silikon. Hvis du er usikker, be om kvalifisert hjelp. Tilkobling av møblene til vann-/avløpsnettet må utføres utelukkende av autorisert personell. Distributør: S.C. Savinidue S.R.L.
- [HR]** Namještaj se mora pričvrstiti na zid. Pakiranje ne sadrži tiple i vijke za pričvršćivanje na zid. Odabiru se ovisno o vrsti zida. Koristit će se posebni montažni setovi za pričvršćivanje umivaonika dostupni u specijaliziranim trgovinama. Za pričvršćivanje umivaonika na tijelo upotrijebite sanitarni silikon. Ako niste sigurni, zatražite stručnu pomoć. Spajanje namještaja na vodovodnu/kanalizacijsku mrežu mora izvršiti isključivo ovlašteno osoblje. Distributer: S.C. Savinidue S.R.L.
- [SL]** Pohišstvo mora biti pritrjeno na steno. Paket ne vsebuje mozničkov in vijakov za pritrditev na steno. Ti se izberejo glede na vrsto stene. Uporabljeni bodo posebni montažni kompleti za pritrditev umivalnika, ki so na voljo v specializiranih trgovinah. Za pritrditev umivalnika na ohišje uporabite sanitarni silikon. Če niste prepričani, poiščite usposobljeno pomoč. Priključitev pohištva na vodovodno/kanalizacijsko omrežje mora izvesti izključno pooblaščen osebje. Distributer: S.C. Savinidue S.R.L.

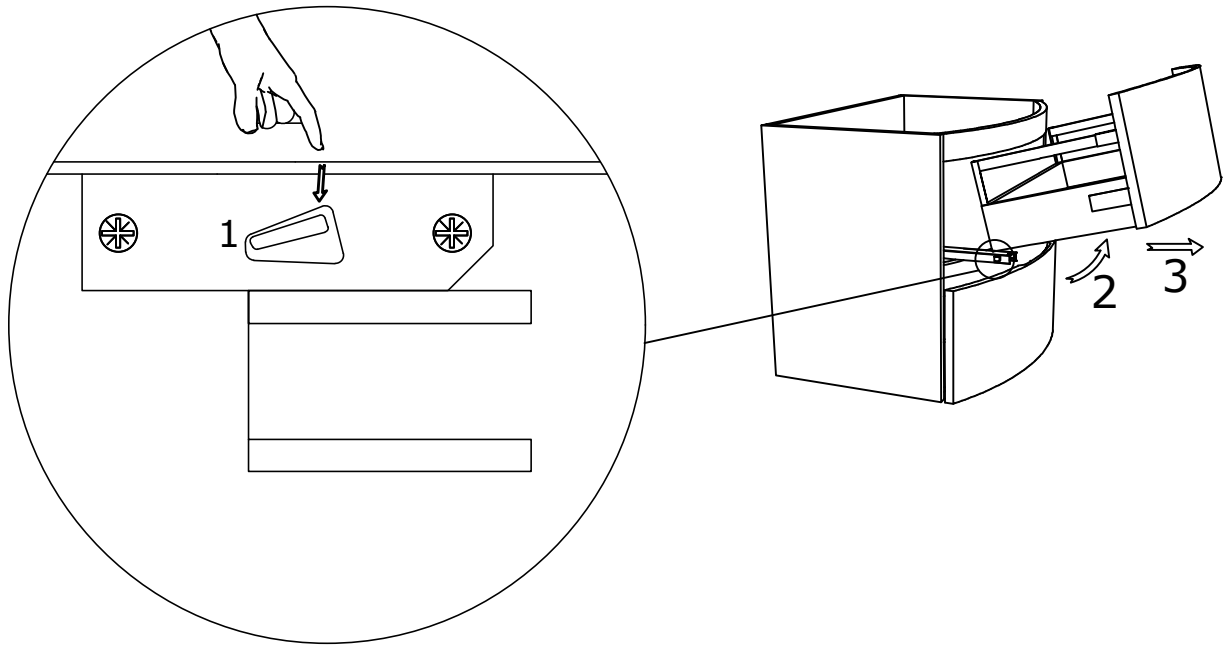

25kg  
MAX



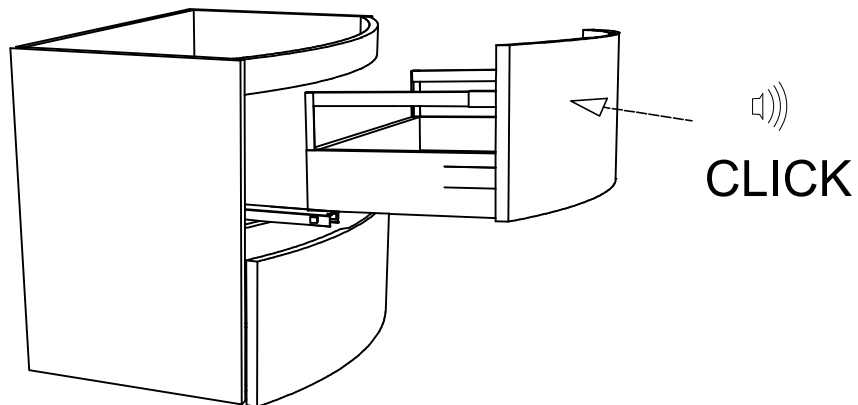

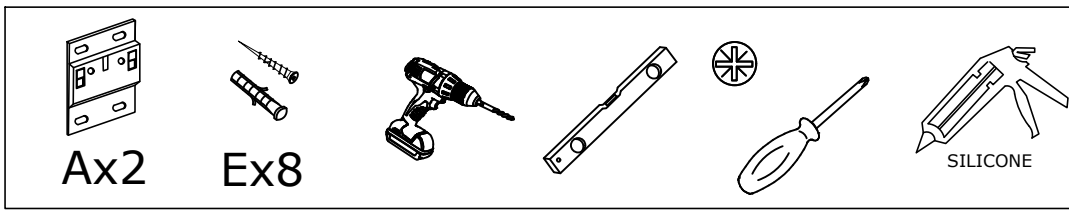
I.

1.

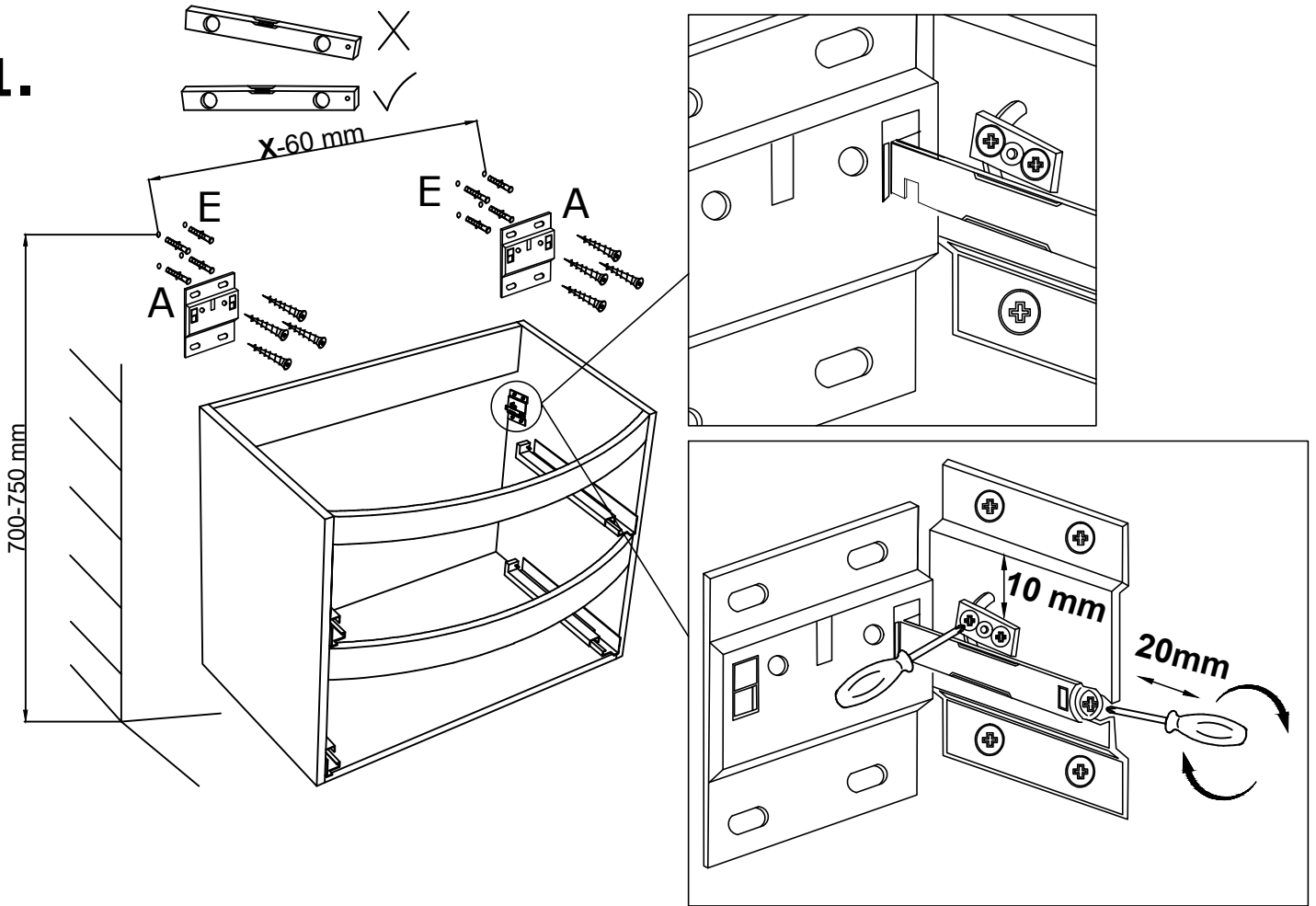

2.

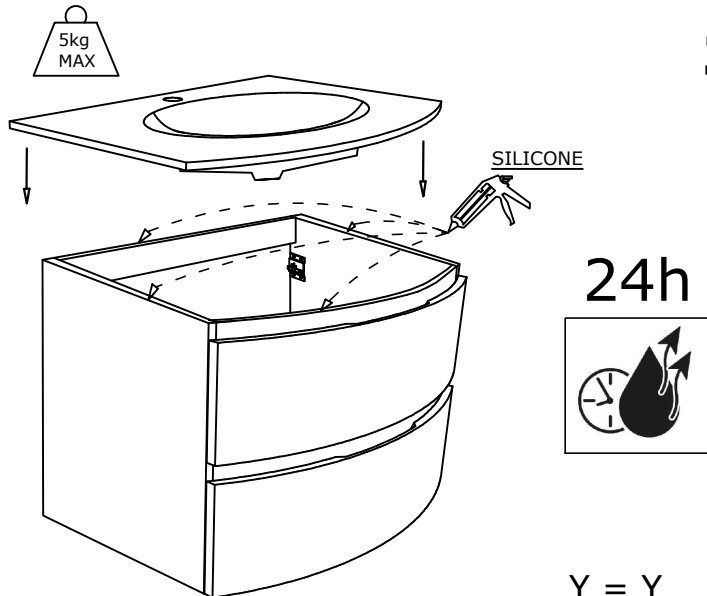

3.

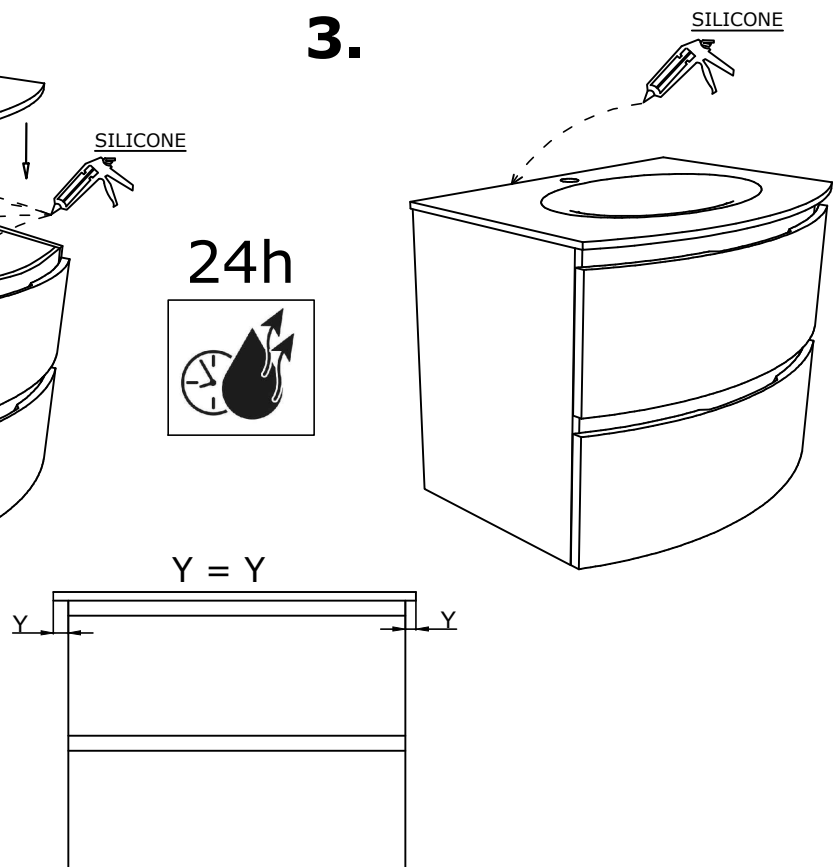

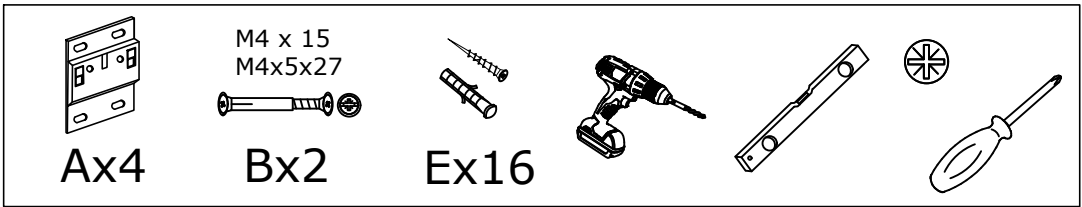

II. & III.

1.

II.

III.

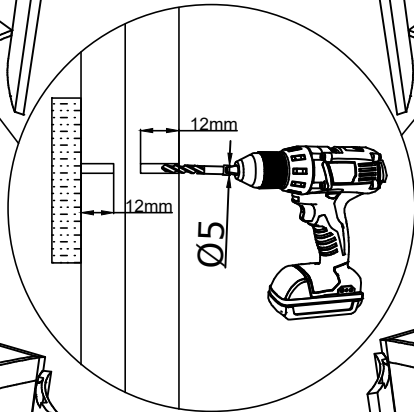
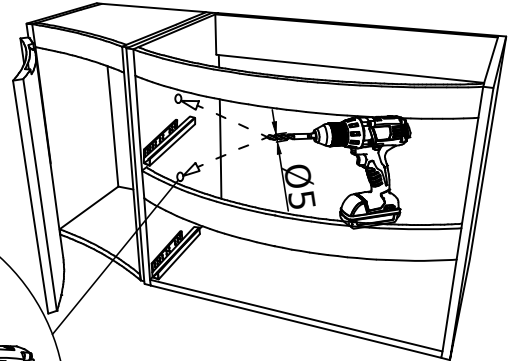
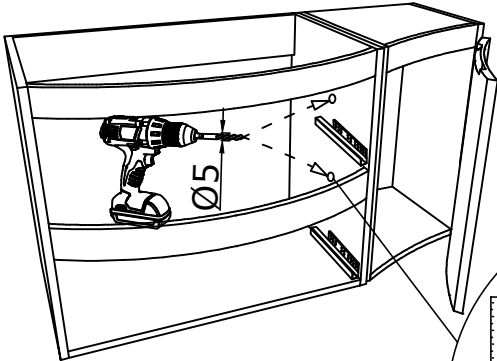

2.

II.

III.

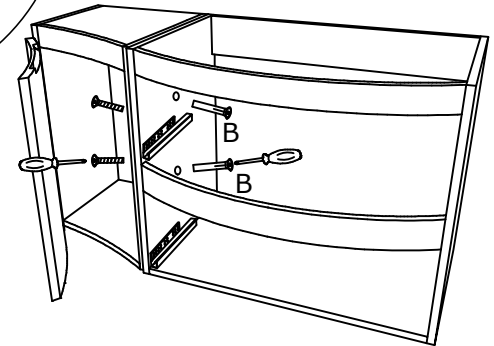
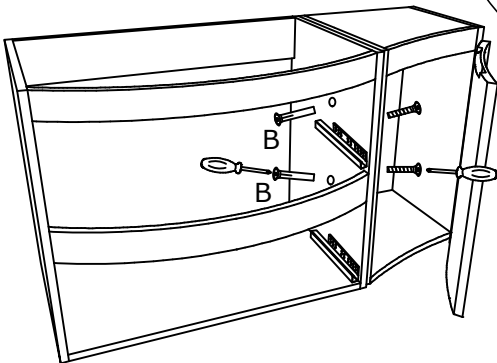

3.

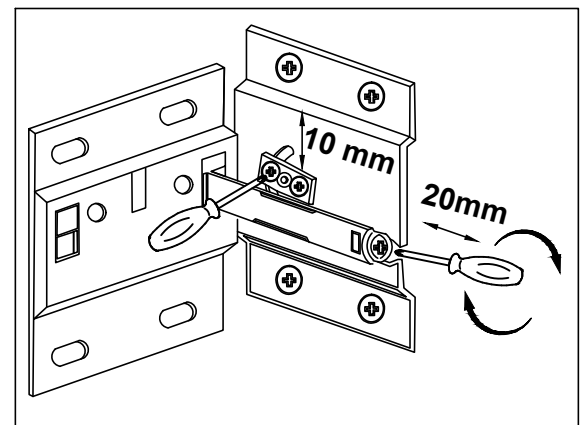
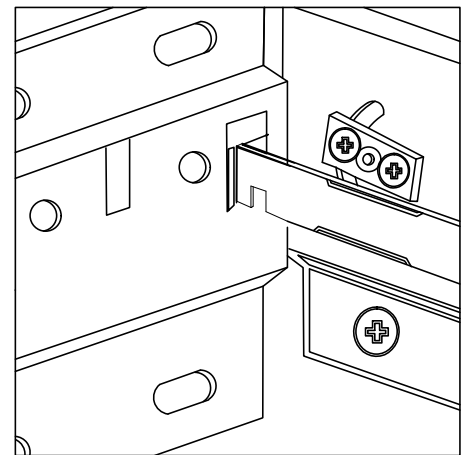
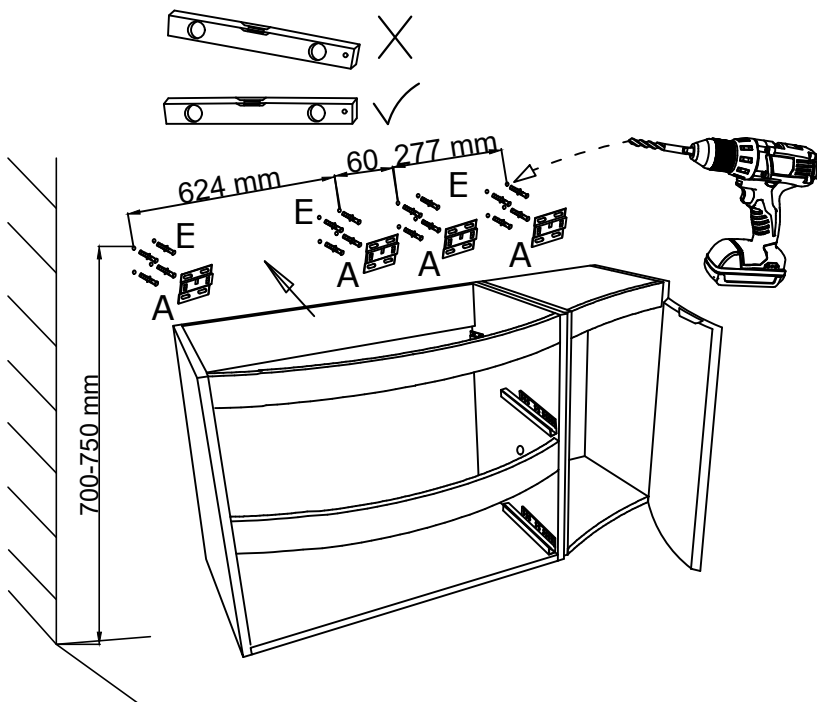

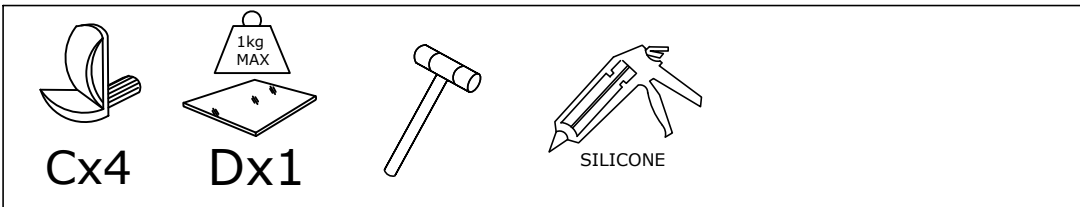

# II. & III.

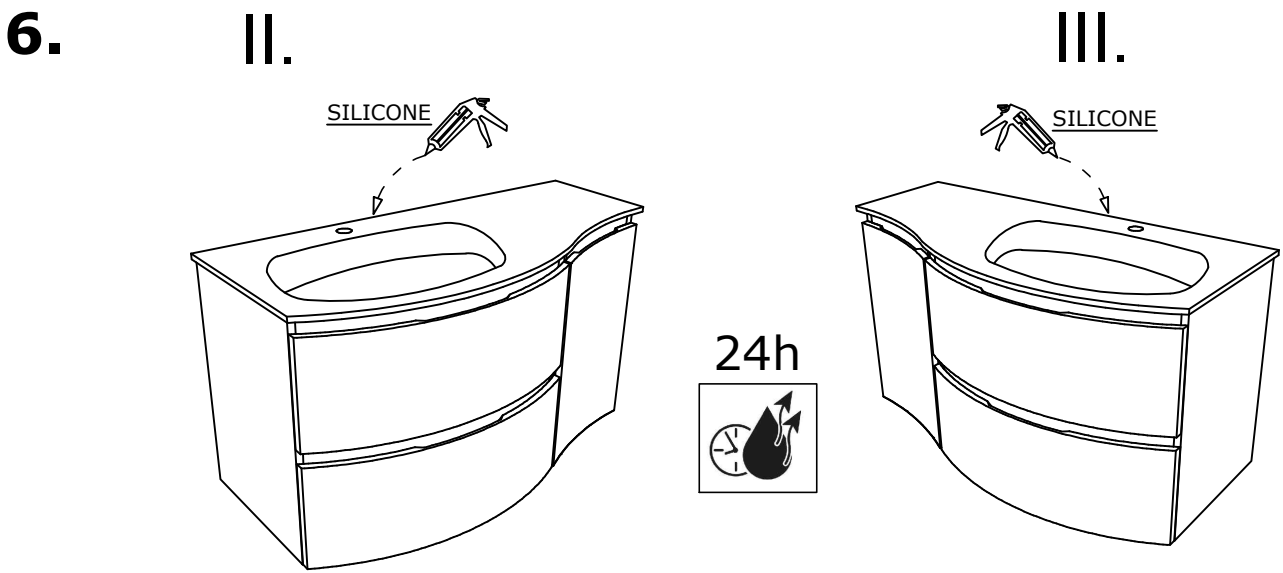
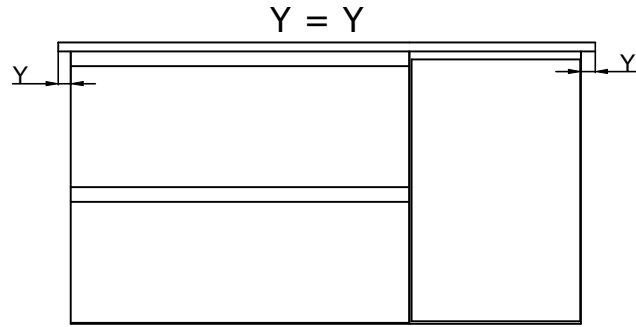
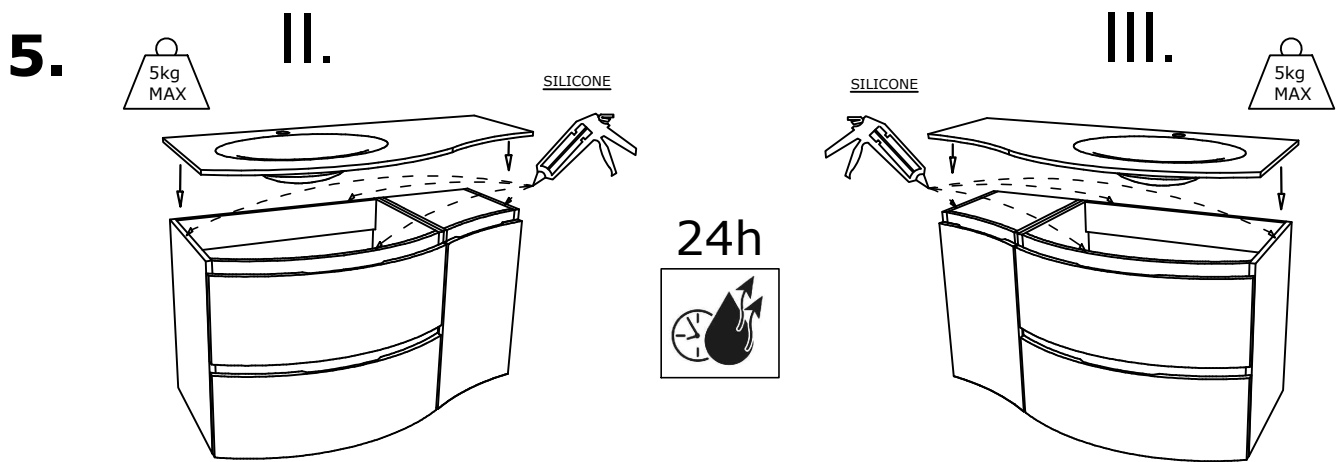
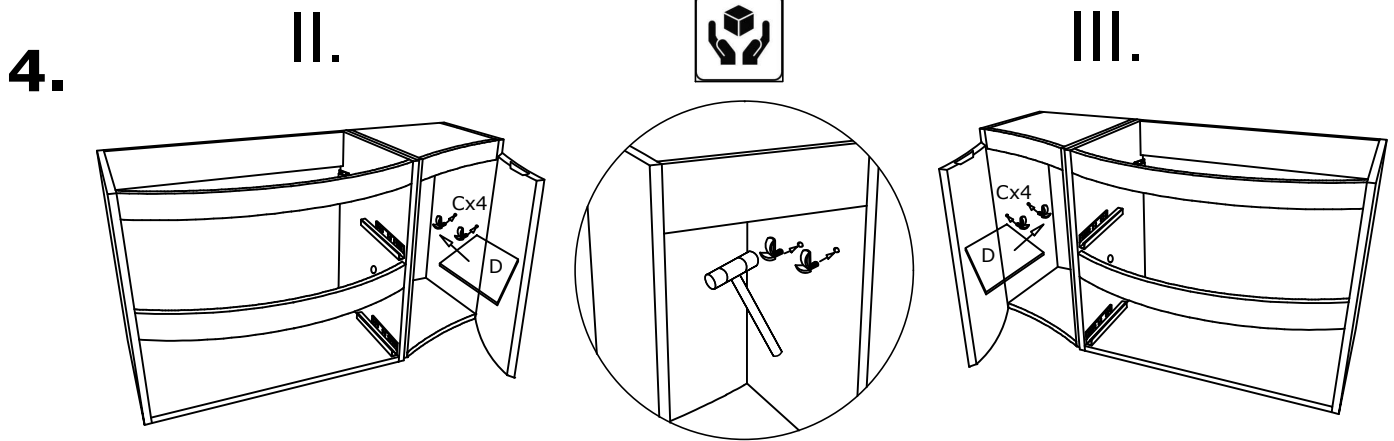

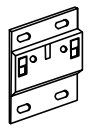

Ax4

M4 x 15  
M4x5x27

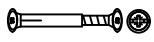

Bx2



Ex16

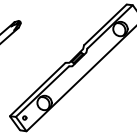

SILICONE

# IV.

## 1.

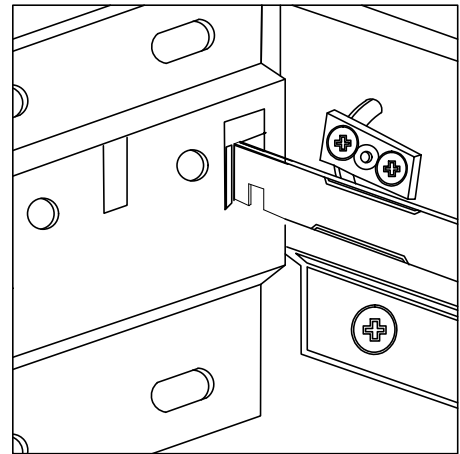
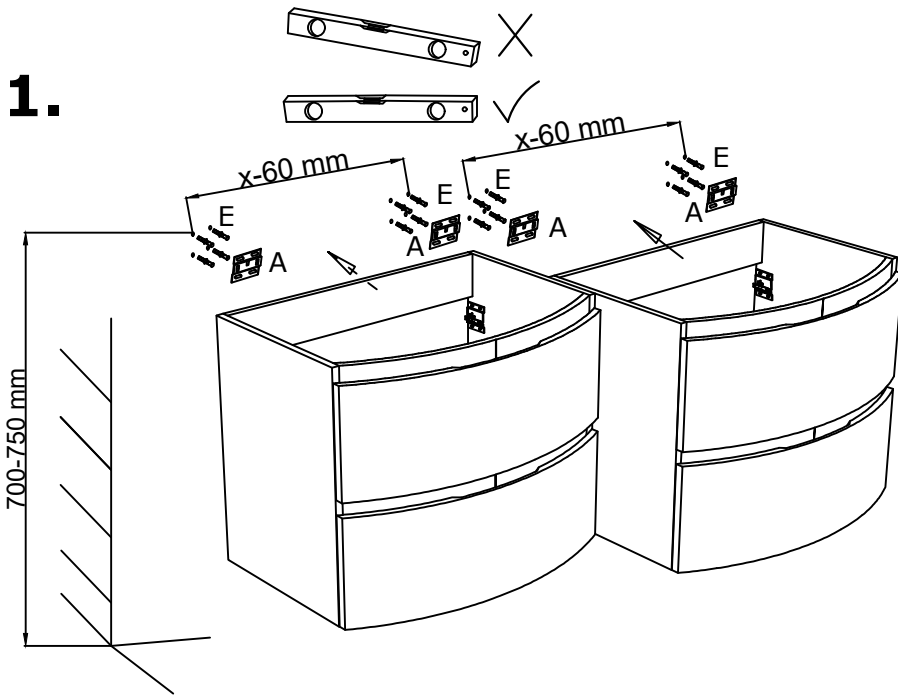

## 2.

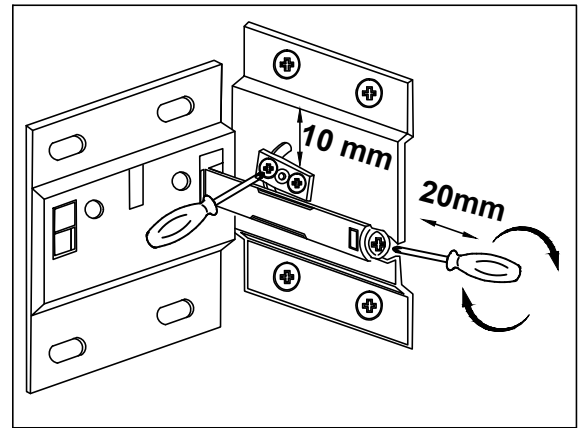
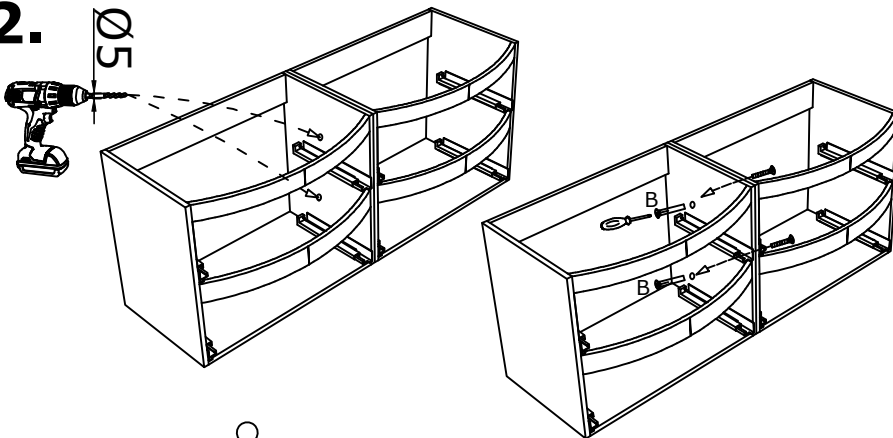

## 3.

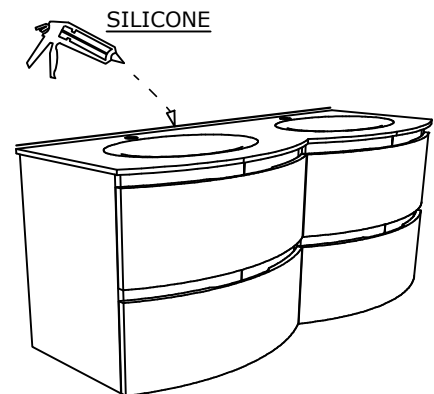
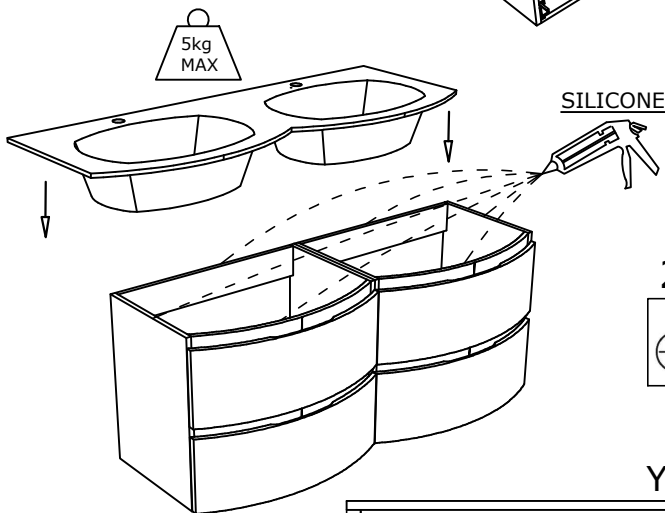



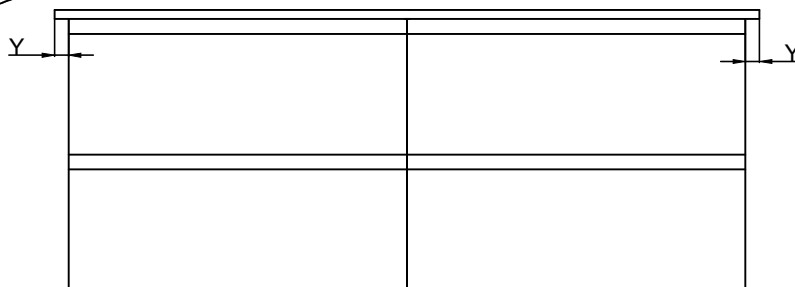

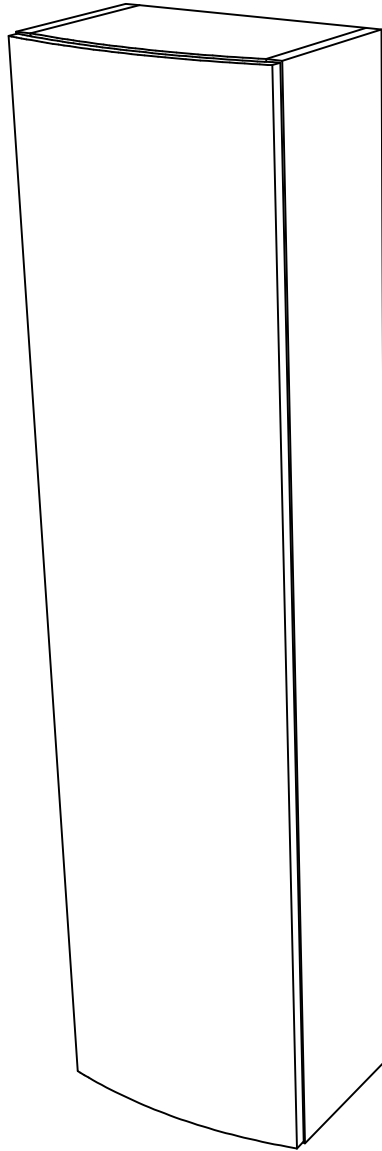



Y = Y



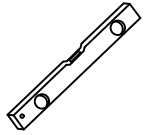
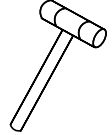

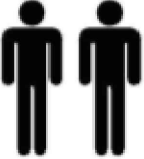
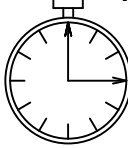
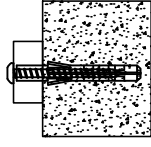
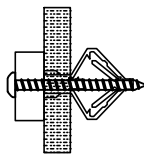
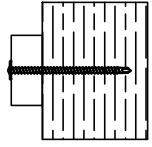
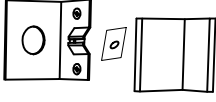
CU335-AR-GW  
CU335-AR-BM  
CU335-AR-RO  
CU335-AR-SA  
CU335-AR-NM  
CU335-LY-WM  
CU335-LY-GS  
CU335-LY-MA  
CU335-LY-TA  
CU335-LY-TP  
CU335-LY-VI

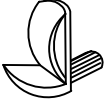
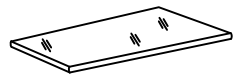
						 Ex2
	 40m	 Ø8	 Ø8	 Ø5		
 Ax2	 3.5X16 Bx4	 Cx16	 Dx4			

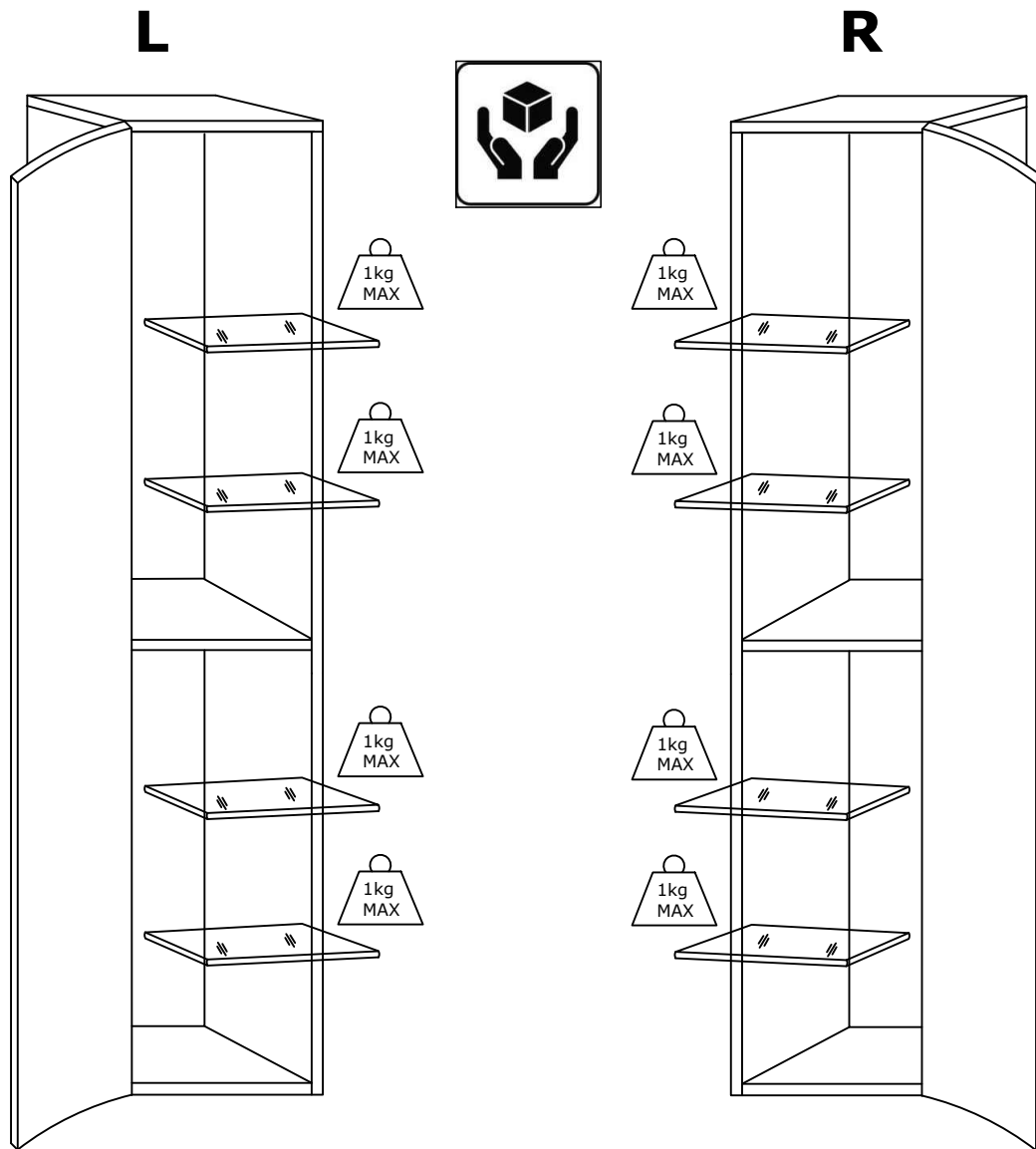

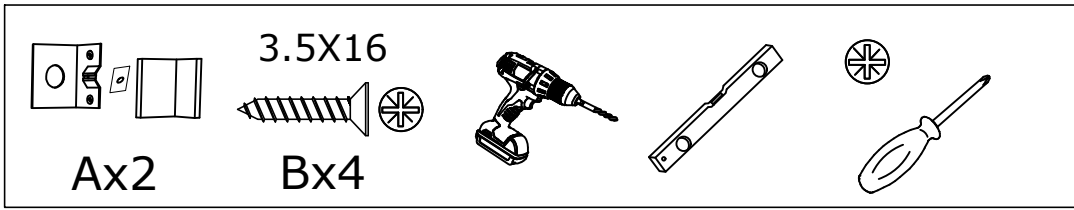

**L**

**R**

**1.**

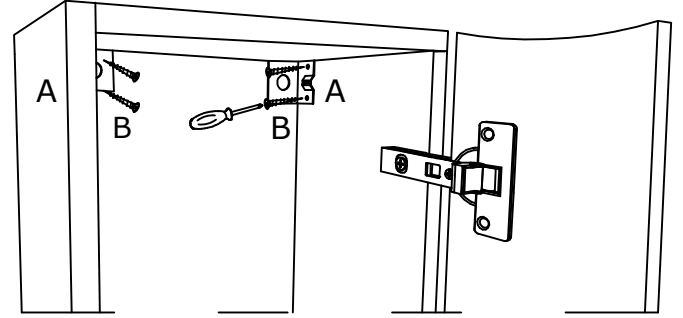
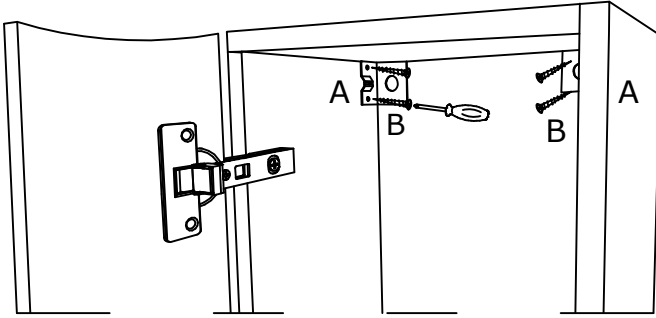

**2.**

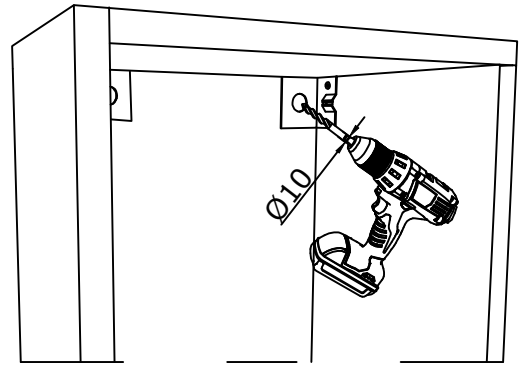
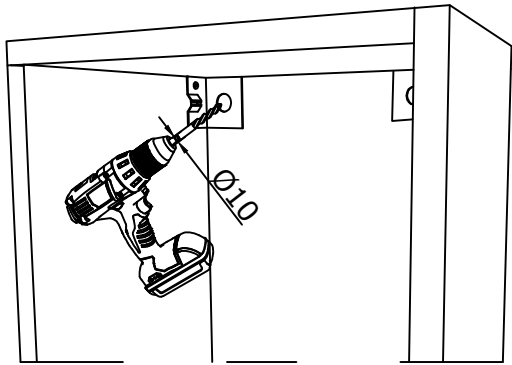

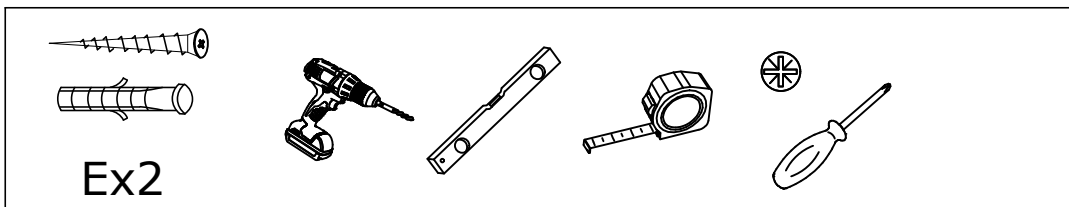

3.

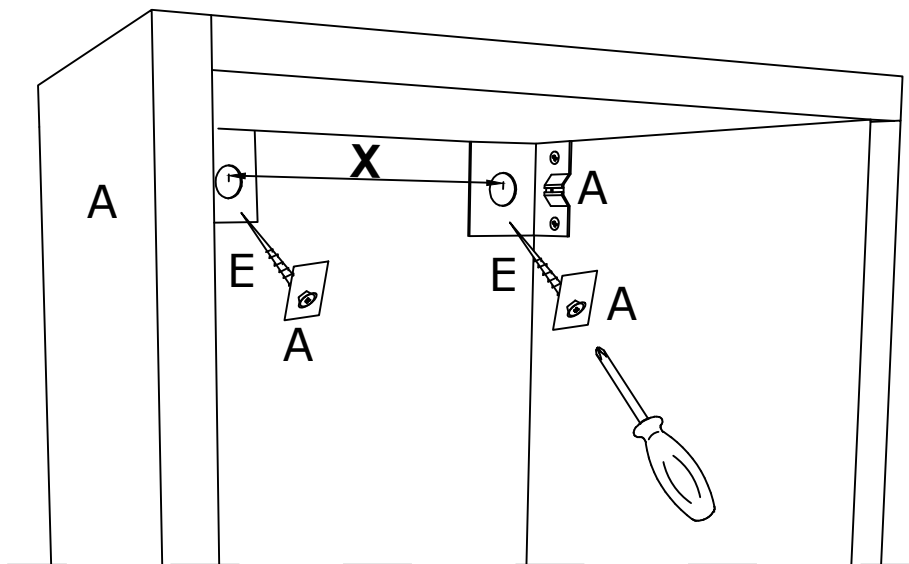
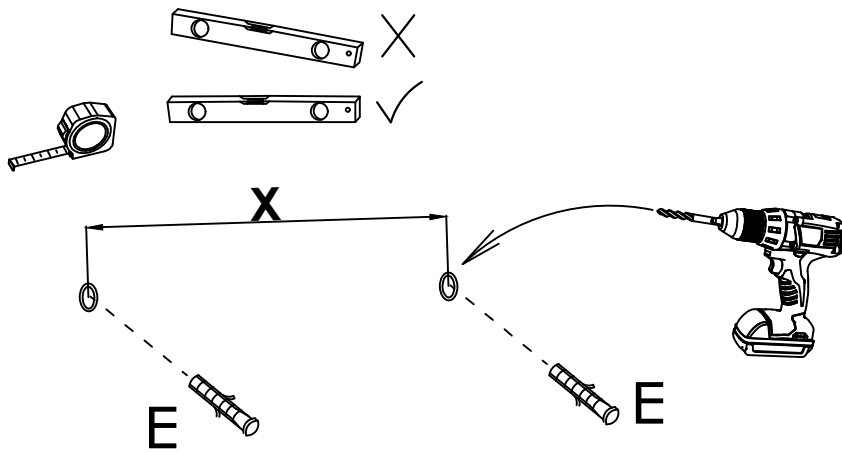

4.

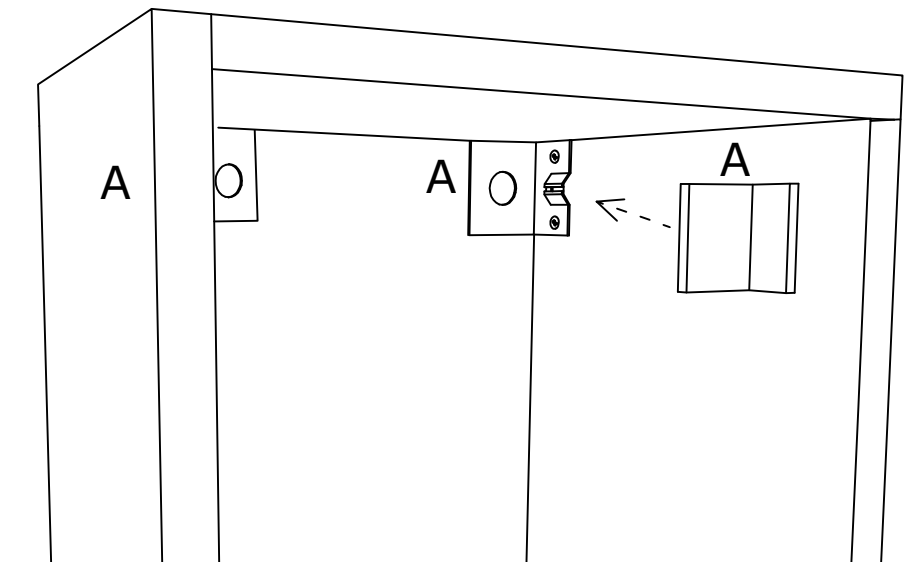

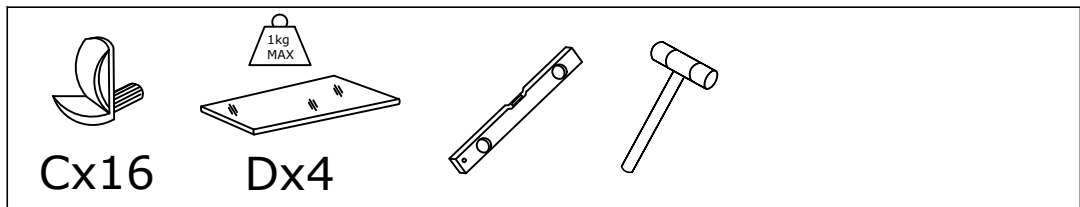

4.      L

R

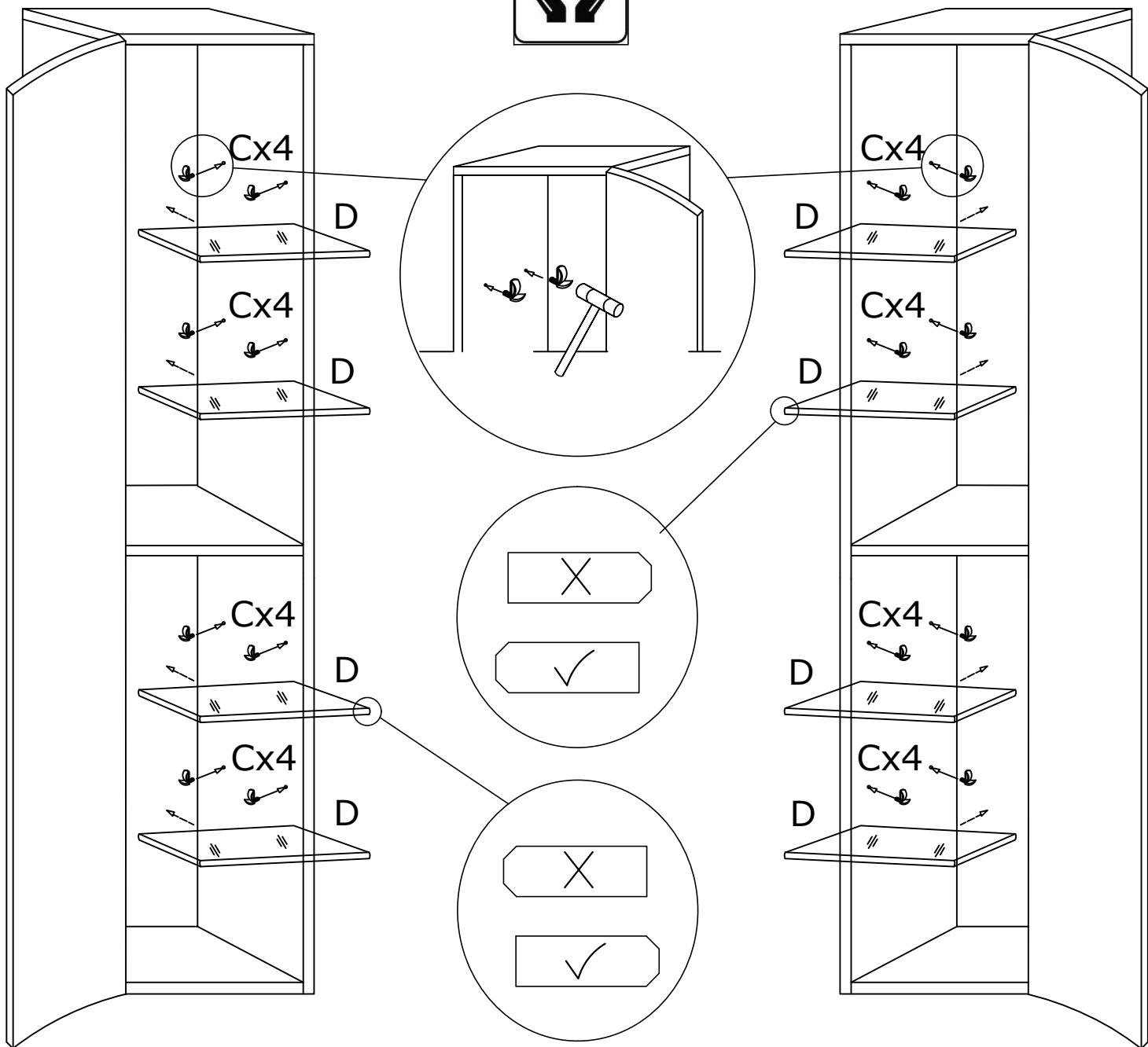



875 rue de Thiers  
42430 ST-JUST-EN-CHEVALET  
France

Tél. 04 811 707 00  
email : [contact@saniverre.fr](mailto:contact@saniverre.fr)  
site web : [www.saniverre.fr](http://www.saniverre.fr)

**Responsable économique dans l'UE**

Savini Due SRL  
100A Strada Augustin Bena  
515800 SEBES Romania  
[contact@savinidue.ro](mailto:contact@savinidue.ro)



Adresses sur [quefairedemesdechets.fr](http://quefairedemesdechets.fr)